

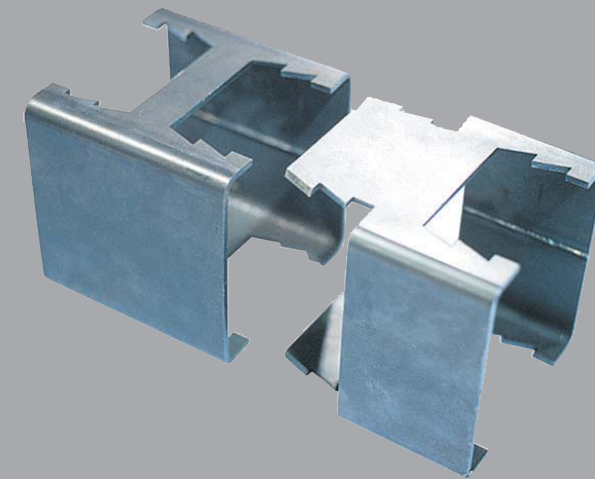

THE LASER CUTTING CO

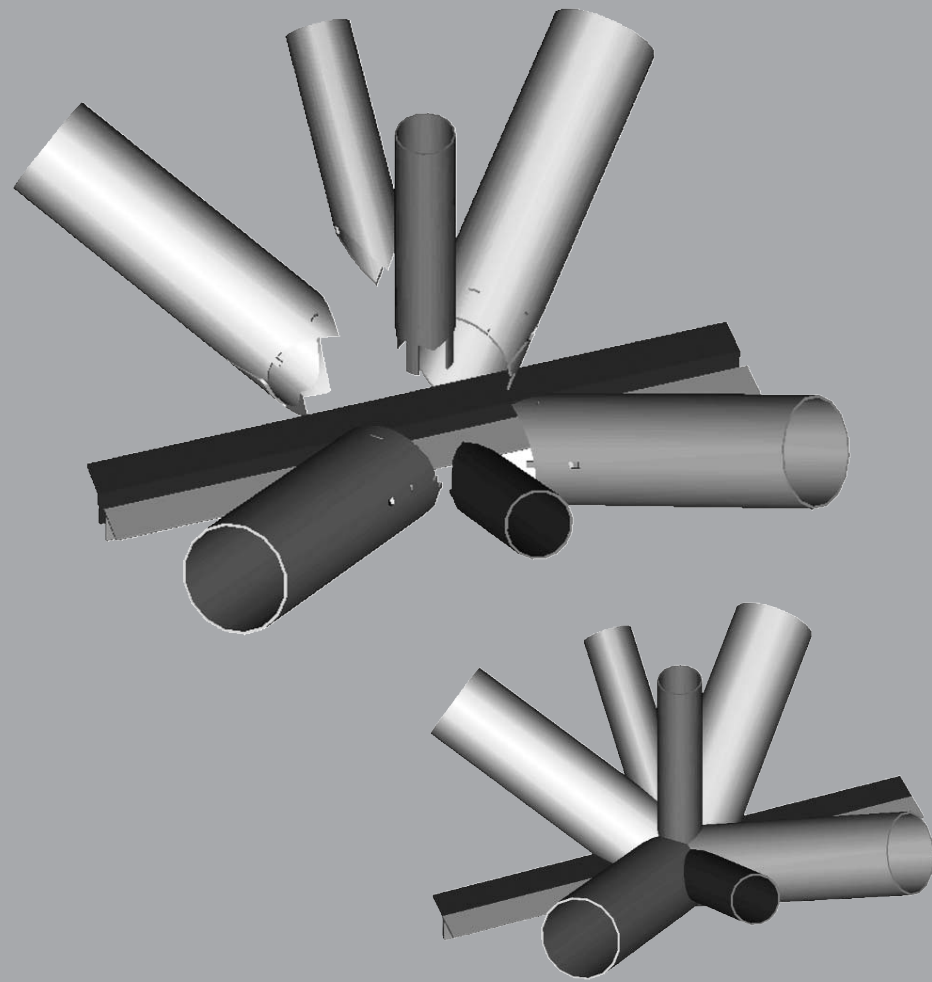

● Expanding

The Laser Cutting Co. Ltd.
Tel: 0845 337 3171
Email: metal@lasercutting.co.uk

● Your

Catley Road Sheffield S9 5JF
Fax: 0845 337 3172
www.lasercutting.co.uk

● Possibilities



● Tubes & Structural Sections



First in the UK.....



● **Structural Sections - beams, pipes, tubes & special sections**

● **6 Axis - 3D Cutting Head - with automatic feed for faster throughput**

● **Compound Angle - weld prep bevel - for an accurate fit, first time, every time**

● **A technological leap forward for weld integrity**

● **Minimum heat affected zone when compared to plasma cut**

● **Giving you real savings in both time and cost by avoiding multiple processes**

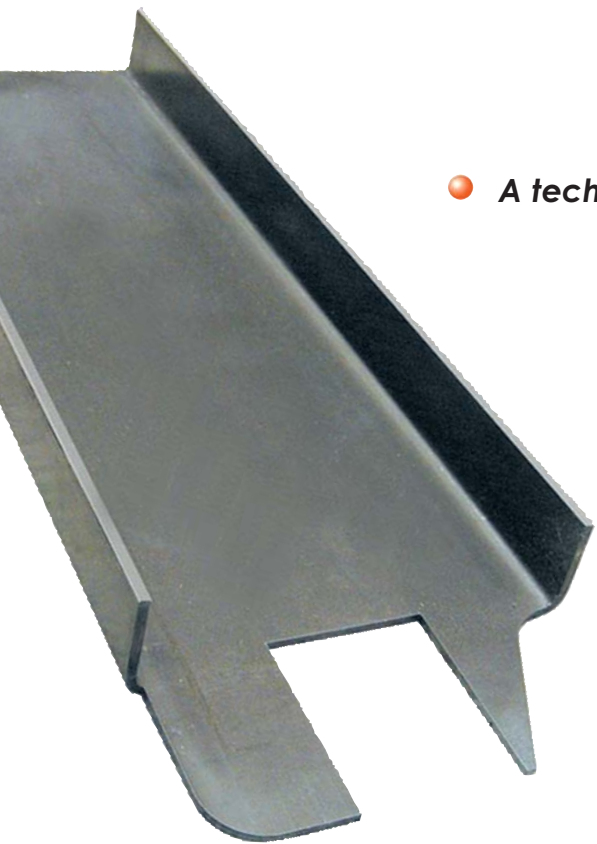

The Laser Cutting Co.....



The Laser Cutting Co established in 1981 provide a quality, customer focused, sub contract cutting service delivering tubular, structural sections, beams, pipes and flat/bent metal components on a daily basis to customers throughout the UK. The Laser Cutting Co is a one stop shop for customer's primary metal fabricating needs.

Our latest 6 Axis – laser cutting facility sited in the heart of the UK is capable of processing 3 dimensional parts including tube, pipe and structural sections up to 8 metres (26 ft) long in automatic feed mode.

This new process offer customers the facility to avoid or minimise separate processes such as sawing, milling, drilling and plasma cutting etc which necessitates considerable movement and handling of material. Traditionally items can be handled 6 or 7 times, involving set-up at each operation, these labour intensive actions can now be achieved in one process.

For example, a tab and slot design can eliminate the need for expensive jigs. A mitre joint finished with a weld prep bevel not only reduces welding time but adds guaranteed accuracy and improves appearance, integrity and quality of your finished product.

Complex joint details are accurately cut for fit up and ease of assembly which can considerably reduce 'on site' delays.

Production cut contours and bevels offer an exact fit on saddle joints and multiple intersecting pipes.

The minimal heat affected zone and our ability to cut a compound angle with an integral weld prep bevel gives you the best fit, first time – every time with ultimate weld integrity. These more accurate parts are also ideal for robotic welding.

The Laser Cutting Co relish getting involved with customers design process teams to add value and take out cost – just a 2 hour meeting could save thousands of pounds – why not give us a call

0845 337 3171

See our main brochure for further information on standard tubular, flat and bent parts.



.....for a bigger tube or section, mitre cutting and structural parts

.....your first choice for success